



SCHEIBER

BLOC 10

Ref : 41.70520.00 XXX XXX

User Manuel & Troubleshooting Guide



Acknowledgement.....	P.2
Safety Warnings.....	P.2
Accessories / Associated references.....	P.2
Equipment description.....	P.2
Technical characteristics.....	P.3
Electrical characteristics.....	P.3
Description of the markings used.....	P.3
Installation instructions.....	P.5
Connection.....	P.5
Wiring.....	P.6
Terms and conditions.....	P.7
Warranty terms.....	P.7



SCHEIBER

2 Bellevue, 85120 Saint-Pierre du Chemin • France

Phone : +33 (0)2 51 51 73 21 • clients@scheiber.fr • sav@scheiber.fr • www.scheiber.fr



Acknowledgement

We thank you for your purchase and hope that you are fully satisfied with this product.

Before you use this product, we recommend you read the instructions below carefully. This manual explains how to use and install the product in accordance with its intended use.

Safety Warnings

WARNING: Do not disassemble the device

Any contact with the product's internal components can cause injury. In the event of a malfunction, only a qualified technician is authorised to repair the device

WARNING: In the event of impact

If the product falls or undergoes heavy impact, immediately contact a qualified person to ensure the device is working correctly

WARNING: Unpacking the equipment

After unpacking the product, make sure that it is complete and in good condition. If you are not sure, immediately contact a person with the required professional qualification

WARNING: Unpacking the equipment

Do not leave any part of the packaging within the reach of children or vulnerable adults

Accessories / Associated references

Designation	Reference
120Ω BUS CAN Termination	0D.CRD399
Crimp contacts and 21-point MCP connector	62.SAC12003A.00

Equipment description

Bloc 10 allows 6 momentary switches to be interfaced with a status indicator and a backlight indicator per function.

It interfaces with a Scheiber Multibloc network, in order to retrieve the state of the control switch and to deport the control to a power block (Bloc 9 for example).



Technical characteristics

BLOC 10

REFERENCE	41.70520.00 XXX XXX
POWER SUPPLY	8-32 V DC
DETAILS AND FEATURES OF THE INPUTS	6 minus digital inputs (for momentary switches)
DETAILS AND FEATURES OF THE OUTPUTS	6 outputs MOS 0,7A 0-32VDC for switch status indicators 1 output MOS 0,7A 0-32VDC for switch backlight indicators
CAN BUS	2 x connectors type 6-way Micro-Fit
ENVIRONMENTAL CONDITIONS	Indoor use Altitude up to 2000m Operating temperature: 0 to +50 °C Relative humidity: 0 to 93% - non-condensing Protection index: IP20
MOUNTING	4 screws
MOUNTING DISTANCE	100 x 59 mm
WEIGHT	0,19 Kg
STANDARDS	EN 60945
FIRMWARE VERSION	V8.00 or higher
DIMENSIONS (LxWxH)	160 x 95 x 50 mm

Electrical characteristics

INPUT RATED VOLTAGE (VDC)	8-32 VDC
SELF-CONSUMPTION	45 mA
MAXIMUM CURRENT PER OUTPUT	0,7A
MAXIMUM CUMULATIVE CURRENT	5A
OUTPUT INDICATORS DISJUNCTION THRESHOLD	0,7A

Description of the markings used

V	Volt
A	Ampere
≡ ou DC	Direct current

Seen from above

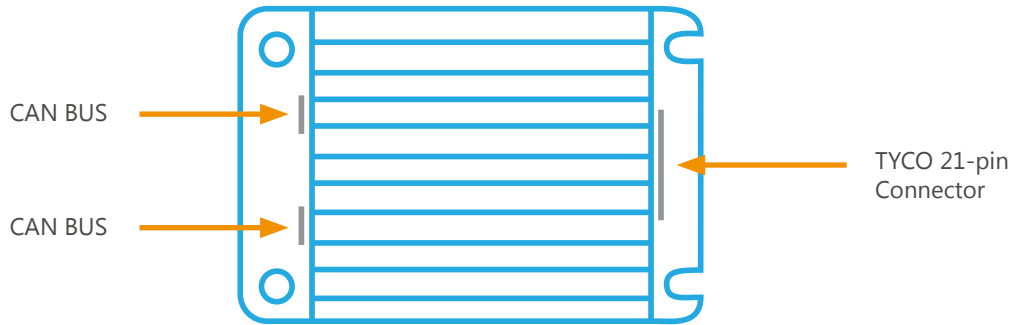

Left side view

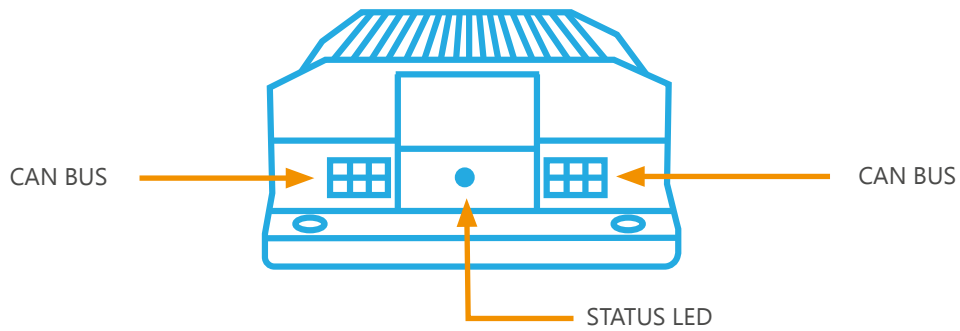

Right side view

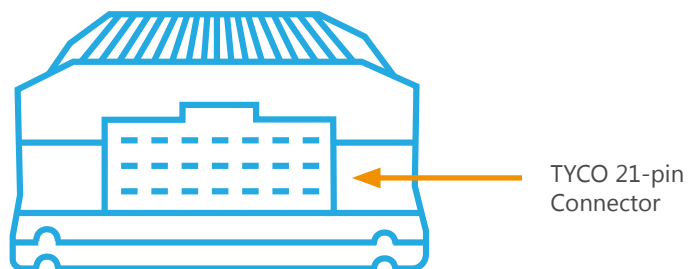

Installation instructions



SCHEIBER

- This device must be placed in a place protecting it from any risk of water splashing. Install in a ventilated location
- Do not install on supports that are sensitive to heat, such as carpet or PVC flooring, etc.
- The product must be installed away from heat and humidity



WARNING: Connection/disconnection with power on
Do not perform connection or disconnection with power on.

Mounting

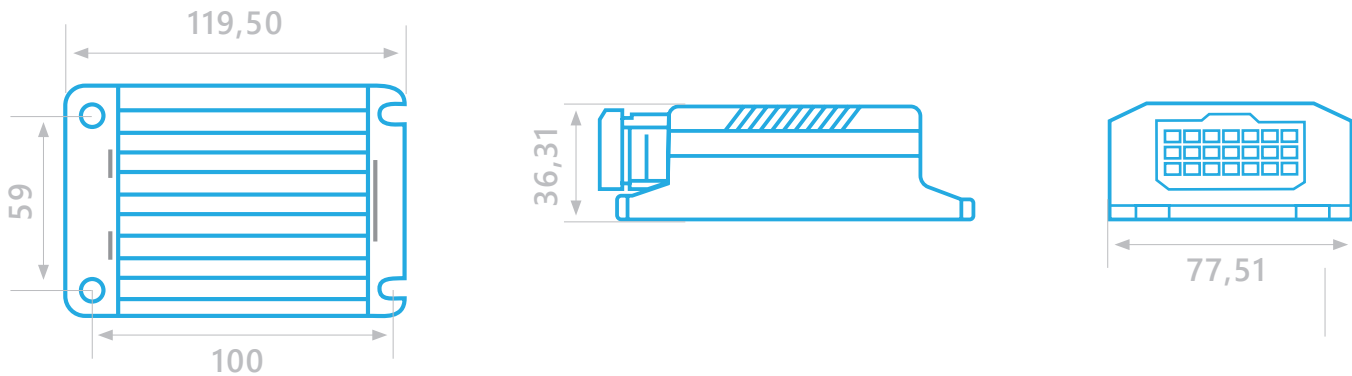

Mounting distance :
100 x 59 mm

Connection

INPUT / OUTPUT / POWER SUPPLY

Type of connection

Cross section

MCP2,8 - 21Pts (BROWN) housing connectors
Ref. Scheiber OE.CON1430
Ref. Tyco 8-968975-1 MCP2,8GEH21P

MCP2,8 Receptacle 0,5-1,0mm2 tinned
Ref. Scheiber OE.CLP360
Ref. Tyco 1-968849-1

Extraction tool for MCP contacts
Réf. Tyco 1-1579007-2

CAN BUS

2 x CAN connectors type 6-way Micro-Fit

PROTECTION TO BE PROVIDED ON THE SUPPLY LINE

Protection rating

Protection location

Fuse or circuit breaker 5A

Accessible and identified for the user

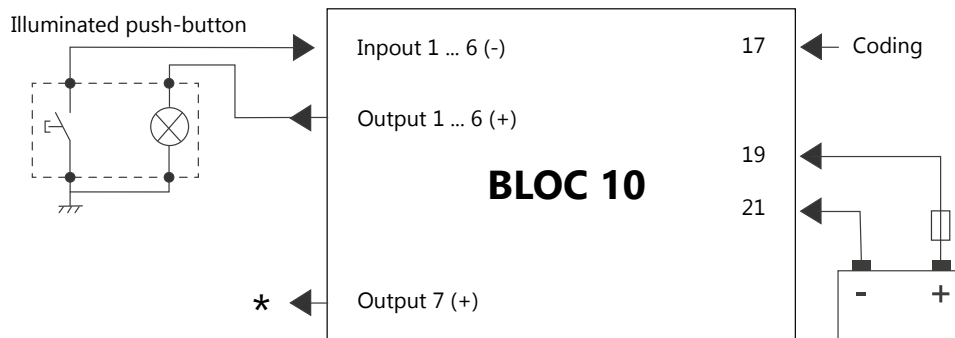

* To power a backlight indicator for example



P.5

Wiring

- ① Connect to each connector:
- either a CAN connection cable (to another Multibloc compatible device)
 - or a 120Ω impedance matching plug.

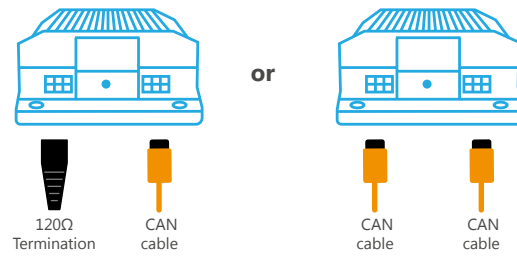

- ② Connect the equipment to the pins according to the numbering available in the table below, then plug the MPC connector into the TYCO receptacle.

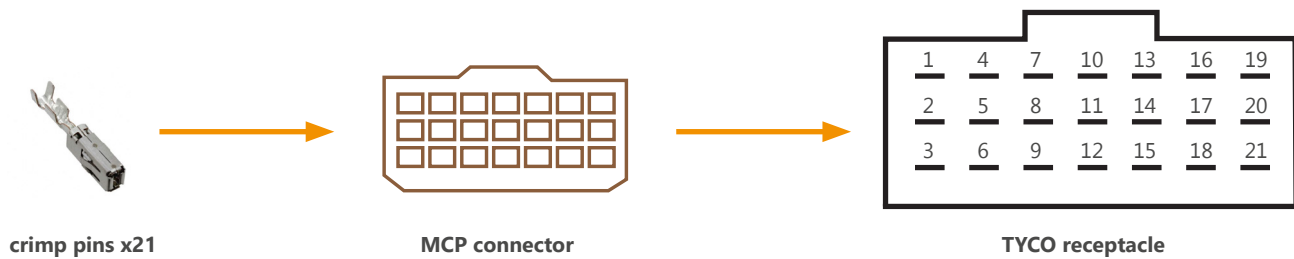

Crimp pin	Designation	Description
1	S1	Output + indicator N°1
2	/	NC
3	E1_NUM_MOINS	Minus digital input for momentary switches N°1
4	S2	Output + indicator N°2
5	/	NC
6	E2_NUM_MOINS	Minus digital input for momentary switches N°2
7	S3	Output + indicator N°3
8	/	NC
9	E3_NUM_MOINS	Minus digital input for momentary switches N°3
10	S4	Output + indicator N°4
11	/	NC
12	E4_NUM_MOINS	Minus digital input for momentary switches N°4
13	S5	Output + indicator N°5
14	/	NC
15	E5_NUM_MOINS	Minus digital input for momentary switches N°5
16	S6	Output + indicator N°6
17	Coding	Coding input
18	E6_NUM_MOINS	Minus digital input for momentary switches N°6
19	+ BAT	Power supply input 8-32VDC
20	S7	Output + backlight indicator
21	MASS	Battery mass



Terms and conditions

The manufacturer cannot be held responsible and accepts no responsibility in the event of harm to persons or property due to improper use and in reference to the warnings provided in this manual.

SCHEIBER reserves the right to change the characteristics of its products in the interest of its customers. The manual supplied with this product must not be reproduced, transmitted, stored in a search system or translated into any language, in full or in part, by any means, without the prior written consent of SCHEIBER.

Although every effort has been made to provide you full and accurate information in this manual we ask that you inform the SCHEIBER representative of your country in case of any error or omission we may have overlooked.

SCHEIBER reserves the right to change the characteristics of the hardware and software described in these manuals at any time and without prior notice.

Warranty terms & after-sales

WARRANTY SUBJECT:

The company SCHEIBER warrants all its products' range against failures or masked-failures according to the article 1641 and followings of the Civil Code. Repairs and replacement of the equipment during the warranty period do not change terms or time of this warranty which is of 2 years. Repairs and replacement of the faulty parts under warranty are made only on presentation of the invoice which certifies the warranty beginning date.

WARRANTY DOES NOT APPLY:

This warranty can not be applied in case of misuse, wrong installation, repair by anyone else than a SCHEIBER authorised technician, damage arising from improper use (fuses replaced by another value), utilisation in an unsuitable environment or if the equipment has suffered from physical damages through handling, transport. It does not cover calibration or verification due to the normal age of the components. Warranty modalities: The equipment freight will be charged to the customer. If the returned equipment is not conform, our company considers it has the right to refuse the free repair and proposes an estimate.

RESPONSIBILITY LIMITS:

In any case, the company SCHEIBER will not be held responsible for direct damages or damages not due to the normal use of the equipment. In case of a dispute arising between the parties, the case shall be submitted to the French Right to the court specified by the company SCHEIBER.





SCHEIBER

L'innovation française depuis 1965

Question ?

contact@scheiber.fr



Problem ?

sav@scheiber.fr

2 Bellevue,
85120 • Saint-Pierre du Chemin
France

Phone : +33 (0)2 51 51 73 21
sav@scheiber.fr
www.scheiber.fr